

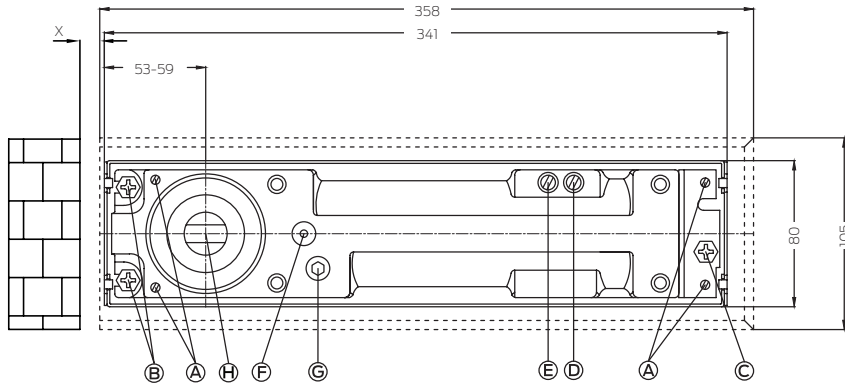

F8500 Floor Spring Installation Instructions

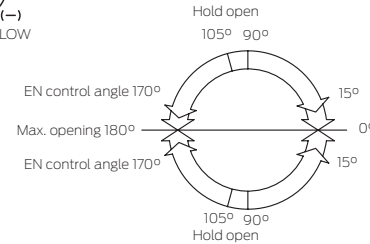

Speed adjustment valve ④ ⑤



Adjustment Instructions:

1. Install the provided cement box
2. Loosen fixing screws B and C, place floor spring into cement box
3. Adjust screws A to adjust the position of the floor spring and ensure that the floor spring is levelled, using F Lever Meter as a guide
4. Re-tighten fixing screw B and C
5. Exchange of spindle insert (if required):
 - Loosen H with Allen key and remove standard spindle insert. Insert extended spindle
 - Fix extended spindle into closer and tighten
6. Power Size Adjustment:
 - Adjust G according to the power size required. Refer to table on the number of turns of spring adjustment nut required based on the power size
7. Adjustment of closing speed and latching speed:
 - The closing speed can be adjusted by regulating valve D. The closing speed ranges from 170° to 15°
 - The latching speed can be adjusted by regulating valve E. The latching speed ranges from 15° to 0°
 - Turn clockwise to decrease closing/latching speed and anti-clockwise to increase closing/latching speed
8. Cover plate fixing:
 - Place cover plate on floor spring body and secure with 4 fixing screws provided

In accordance to EN 1154:1996

Closer Size	Max. Door Width	Max. Door Weight (Based on EN)	Max. Opening Angle	Direction of Adjustment	Power Size Adjustment (Full turns of spring adjustment nut)
2	850mm	40kg	180°	Counter-clockwise	-12
3	950mm	60kg	180°	Default	0
4	1100mm	80kg	180°	Clockwise	+18
5	1250mm	100kg	180°	Clockwise	+48
6	1400mm	120kg	180°	Clockwise	+68

F8500 can hold door weights of up to 300kg

Important Notes:

- ⚠ Maintenance – Check the door closer every three months to ensure all fixings are secured. Adjust the closing and latching speed if necessary
- ⚠ Warning – The door closer contains pre-stressed spring which is inserted into the floor spring body under pressure. Please do not attempt to dismantle the door closer
- ⚠ Sealing compound (optional) – If the floor spring is being installed in an area exposed to the external environment, apply a sealing compound to protect it. Before applying the sealing compound, ensure that all adjustments to the floor spring have been properly configured.



Allegion (SEA) Pte Ltd
Phone (65) 6227 7318

Allegion Hong Kong Limited
Phone (852) 2235-0600

Allegion (Thailand) Limited
Phone (66) 2051 4141

Allegion India Private Limited
Phone (91) 080 66798700

Allegion (Korea) Inc.
Phone (82) 70 8287 1353

Email sea.info@allegion.com
www.allegion.com.sg