

# Briton

## EH300 Series Hinges



The EH300 series hinges certified to **EN1935**. This certification ensures that the hinges have undergone rigorous testing.

## Features

- **Comply to the European standards** - Certified to EN1935 G14
- **Exceptional Durability in Harsh Environment** - Manufactured with premium 304 stainless steel material and 316 stainless steel material upon request
- **Convenient Installation** - Each set of hinges is supplied with 8 pieces of machine screws and 8 pieces of wood screws by default
- **Versatile Sizing Options** - Various sizes are available to accommodate different project requirements

# Technical specifications

<b>Model</b>	EH300 Series			
<b>Ball Bearing</b>	4-ball bearings		2-ball bearings	
<b>Dimensions (L/W/D)</b>	Metric (mm): 127/89/3 Imperial ("): 5/3.5/0.118	Metric (mm): 127/89/3 Imperial ("): 5/3.5/0.118	Metric (mm): 102/102/3 Imperial ("): 4/4/0.118	Metric (mm): 102/76/2.5 Imperial ("): 4/3/ 0.098
<b>Door Weight</b>	Up to 100kg		Up to 80kg	Up to 60kg
<b>Compliance</b>	EN1935			
<b>Material</b>	SUS 304 Stainless Steel SUS316 Stainless Steel is available upon request.			
<b>Finishes</b>	Satin Stainless Steel / Polished Stainless Steel For information on other finishes, please consult your sales representative.			

## Dimensions

127mm/89mm/3mm, 4-ball bearings

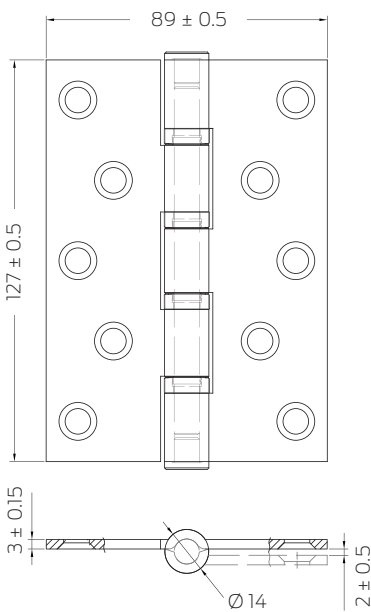

127mm/89mm/3mm, 2-ball bearings

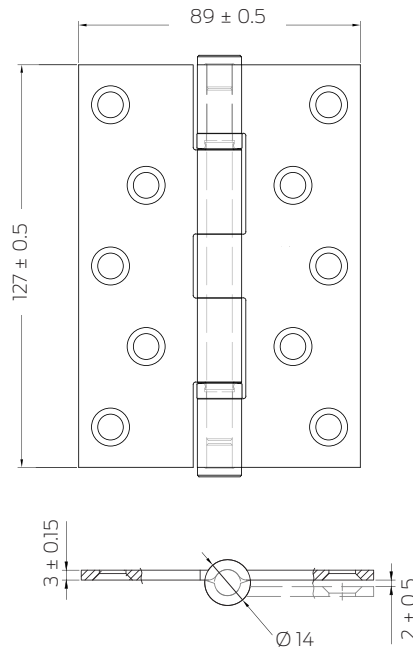

102mm/102mm/3mm, 2-ball bearings

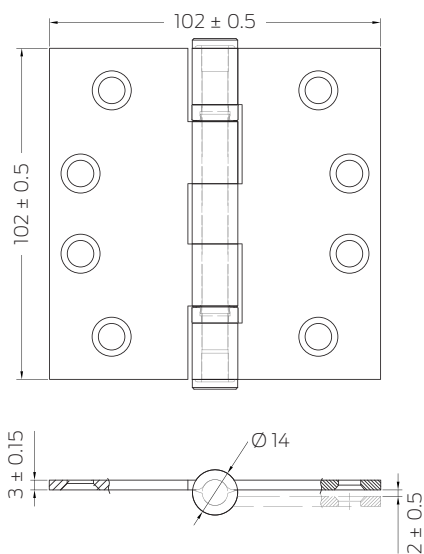

102mm/76mm/2.5mm, 2-ball bearings

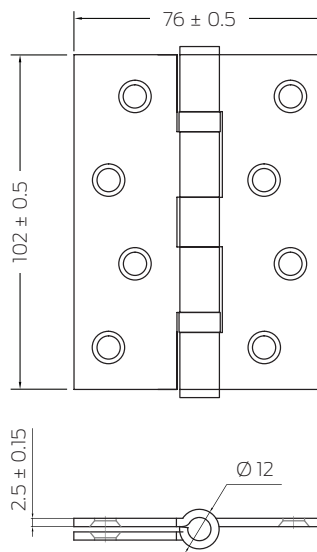

All measurements in the dimensional drawings are in mm.